

# SN12 Countertop Nugget Ice Maker & Dispenser



**Manitowoc**



SN12

- Up to 325 lbs. (147 kgs.) daily ice production.
- Only 16.25" (41.28 cm) wide by 24.00" (61.00 cm) deep by 35.00" (89.00 cm) tall without legs; legs sold separately
- Dimensions of nugget ice are approximately 3/10" x 3/10" x 1/2" (8 x 8 x 12 mm)
- SoftQube® nugget ice provides a softer, chewable texture while still providing maximum cooling effect
- Three dispense settings are standard: ice only, water only, or ice and water
- One-handed ice dispense. Simply place cup under chute and activate
- Two ice activation options: activation arm or touchless
- Dispense opening (10.50"/26.67 cm) from grate to chute maximizes clearance for tall containers
- Larger drain pan minimizes ice spillage
- Blue LED light provides dispense visibility for rooms with limited ambient light
- Water and drain connections in back or bottom of unit for flush mounting
- Manitowoc's patented cleaning technology manages the cleaning process from start to finish
- Warranty  
2-year parts and labor coverage on all components. Additional 3-year (5-year total) parts coverage on ice machine compressor



ISO 9001:2000  
Quality System Certified

**America's #1 Selling Ice Machine**

Ice Cube & Flake Machines • Ice Storage Bins • Ice Dispensers

**Manitowoc**  
Foodservice Group

# SN12 Countertop Nugget Ice Maker & Dispenser

## Space-Saving Designs



	SN12
Height*	35.00" 89.00 cm
Width	16.25" 41.30 cm
Depth	24.00" 61.00 cm
Bin Storage	12 lbs. 5.5 kgs.

\* Height without legs. Legs sold separately: K-00345.

Model*	Ice shape	Ice production 24 hours Based on Air/Water Temp.			Power kWh/100 lbs.	
		70°/50°F		90°/70°F		
SN12A	nugget	325 lbs.	148 kgs.	253 lbs.	115 kgs.	7.11
Water usage/100 lbs./45.4 kgs. of Ice						
Potable Water: 12 gallons, 45.4 liters						

\*A following model number indicates "Air" condensing unit.

Test conditions are 90°F/32°C air, 70°F/21°C water, and 30 ± 3 psig water inlet pressure.

## Ice Machine Electric

115/60/1, (230/50/1 also available.) 115/60/1 ice machines are factory pre-wired with a 6' (180 cm) power cord and NEMA 5-15P-plug configuration. 230/50/1 ice machines are factory pre-wired with a 6' (180 cm) power cord only, no plug is supplied.

**Total ampacity:** Air-cooled: 10.3 amps.

**Maximum fuse size:** Air-cooled: 15 amps.

HACR-type circuit breakers can be used in place of fuses.

SN12

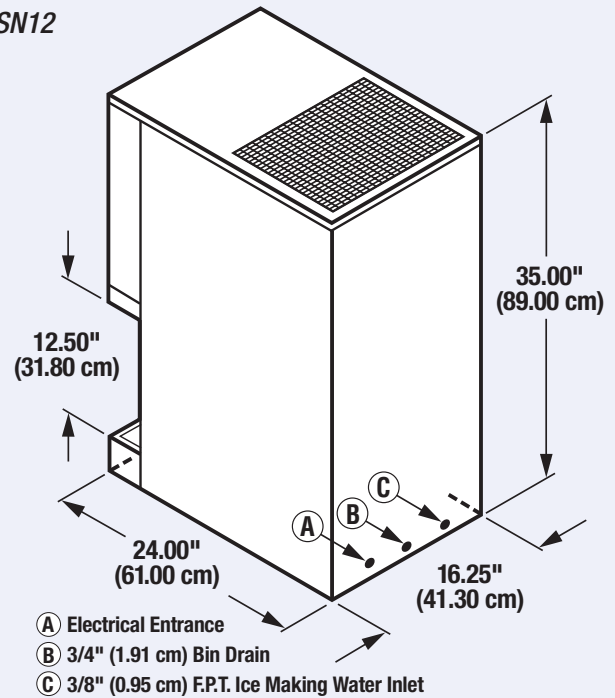

## Specifications

### BTU Per Hour:

2,300 (average)

### Compressor:

Nominal rating: 1/3 HP

**Refrigerant:** R404A

### Operating Limits:

- Ambient Temperature Range: 45°-110°F (7.2°-43.3°C)

- Water Temperature Range: 45°-90°F (7.2°-32°C)

- Water Pressure Ice Maker Water In:

Min. 20 psi (137.9 kPa)

Max. 80 psi (551.1 kPa)

## Front Access



Initiate ice, off, and clean operations with simple upfront selector switch. No need to remove front panel.

## Ice Shape

SoftCube® nugget ice is approximately 3/10" x 3/10" x 1/2" (8 x 8 x 12 mm) with a softer, chewable texture while still providing maximum cooling effect.



## Air Flow Front View

Air in left, air out top.



MANITOWOC ICE, INC.  
2110 South 26th Street, P.O. Box 1720  
Manitowoc, WI 54221-1720, USA  
Ph: 920-682-0161 • Fax: 920-683-7589  
Visit us online at [www.manitowocice.com](http://www.manitowocice.com)

