

Ultra Compact, Low Profile Coffee Brewing Systems



TLP
(Shown with optional 2.5L Airpot)

The Benchmark for ultra compact airpot brewing systems.

Curtis sets a new standard for ultra compact airpot coffee brewing systems with the TLP. This new brewing system combines renowned Curtis brewing expertise with the latest in digital high-technology... Curtis' ADS™ System. ADS design offers precision digital performance, greater reliability and extended working life. Add the new Curtis Advanced Flow Sprayhead (AFS) and you now have total control over BREWING TIME, TEMPERATURE and VOLUME – the three most important aspects of brewing quality gourmet coffee.

Compact design that won't crowd a counter.

TLP models are universally designed and beautifully styled. They offer big performance yet take up little space. They easily fit anywhere from kitchen counter to conference room. Their generous clearance accommodates standard 2.5L airpots and gravity airpots alike.

Features that keep coffee flowing.

The TLP series simplifies the brewing process with standout features. At a glance, the Ready-to-Brew light turns on when the system is set to brew. A handy Hot Water Faucet lets you draw piping hot water anytime.



TLP (Shown with optional Gravity Airpot)

ITEM NO

PROJECT

DATE

FEATURES AT A GLANCE

- **Advanced Digital System** - Delivers precision performance and uses fewer parts for superior reliability.
- **Touchkey Control Panel** - Provides a longer working life than mechanical switches and a smooth surface for easy cleaning.
- **Revolutionary Pump System** - Magnetic drive pump consistently delivers hot water to the AFS Sprayhead for perfect extraction. Seamless housing eliminates leaking.
- **Programmable Brewing Volume** - Factory preset for 2.5L (84.5 oz.) airpots.
- **Brew Cycle Counter** - Keeps track of brew cycles, providing valuable information for Account Qualification, PM Programs, Profitability Reports and more!
- **Programmable Temperature Control** - Factory preset to 200°F. Temperature is easily adjusted in 2°F increments from 170° to 204°F for optimum coffee quality. Keeps brew temperature constant. Easily handles THREE Back-to-Back brewing cycles. Plus, liquid level control interface prevents element burnout.
- **External/Non-Immersed Temperature Sensor** - Eliminates mineral build-up.
- **Self-Diagnostic Digital Control Board** - ADS technology speeds service.
- **Convenient Hot Water** - Draw piping hot water for tea, hot chocolate, soups or cup meals — even during the brew cycle!
- **Revolutionary AFS Sprayhead** - Perfectly saturates the bed of grounds to extract the richest, fullest flavor from every type of coffee, resulting in perfect brew every time.
- **Beautifully Styled Heavy-Duty Construction** - Textured black "gourmet" finish. Optional stainless steel and other finishes available.



Set-Up is Easy! Set-up on the new TLP Low Profile Brewing Systems is easy. Simply plumb in water supply, plug in the system's built-in cord, and turn the machine on. The Curtis ADS System will sense a dry probe and begin filling the tank automatically. Once the water in the tank has reached the proper level, the element will automatically turn on and begin heating. In minutes, the correct brewing temperature will be reached, and you'll be ready to brew!

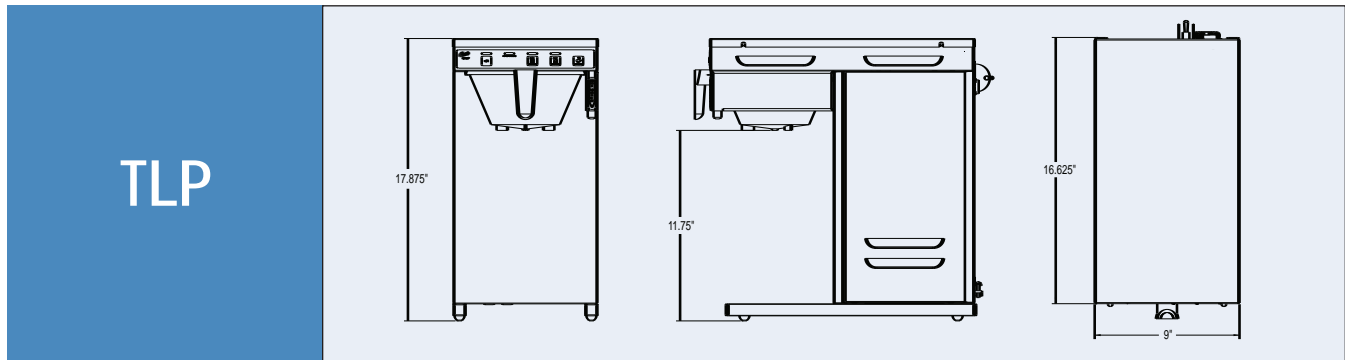

SPECIFICATIONS	TLP
Brewing Heads	1
Finished Brew Capacity -- Full Brew	2.5L (84.5 oz.)
Finished Brew Capacity -- Half Brew	1.25L (42.25 oz.)
Dimensions (H x W x D)	17.875" x 9" x 16.625"
Clearance for Airpot	11.75"
Electrical	120VAC/60Hz
Power Requirements	1500W/12.5A
Cord & Plug	6 ft./NEMA 5-15P
Water Source *	.75" Flare
Shipping Weight (lbs.)	33 lbs.
Cube (cu. ft.)	3.478

*Water Filtration Device Recommended

SPECIFICATIONS	TLXA25	CAP-T1	CAP-T1PS
Finished Brew Capacity	2.5L	2.5L	N/A
Master Pack	6	1	1
Clearance for Airpot	11"	10.5"	Plastic Stand for CAP-T25
Shipping Weight (lbs.)	32 lbs.	5 lbs.	2 lbs.
Cube (cu. ft.)	3.79	.73	.25



WILBUR CURTIS COMPANY, INC.
 6913 Acco Street . Montebello, CA 90640-5403
 Telephone: 800-421-6150 . 323-837-2300 .
 Fax: 323-837-2406
 www.wilburcurtis.com

